

PW redukovaná Y-spojka

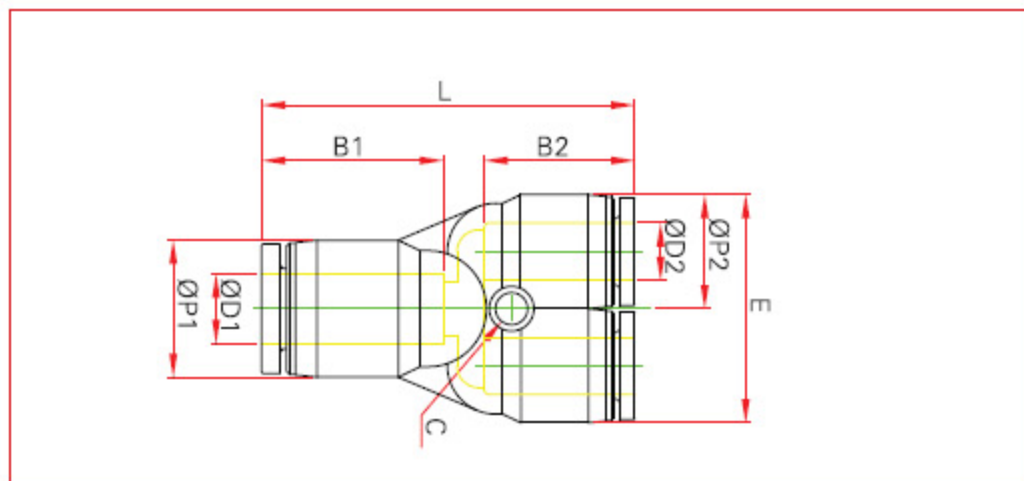

| TYP | ØD1 | ØD2 | L | E | B1 | B2 | C | P1 | PRŮTOK |
|----------|-----|-----|------|------|----|----|-----|------|--------|
| PW-06-04 | 6 | 4 | 36.5 | 22.2 | 15 | 15 | 3.2 | 13 | 3.3 |
| PW-08-06 | 8 | 6 | 37.2 | 26 | 18 | 15 | 3.2 | 14.4 | 4 |
| PW-10-08 | 10 | 8 | 44.1 | 29.6 | 22 | 18 | 4.2 | 18.4 | 5 |
| PW-12-10 | 12 | 10 | 52.2 | 37.2 | 22 | 22 | 4.2 | 21 | 6.4 |