

Angebotszeichnung
QUOTATION DRAWING

Teil-Nr. ITEM-NO.	Stueck QTY.	Benennung PART - NAME	Einzelteilnummer PART-NO.	Werkstoff MATERIAL	Rohstoffnummer MATERIAL-NO.	Oberflaeche SURFACE
1	1	Band / BAND		1.4301 / AISI 304		blank / BRIGHT
2	1	Mutter / NUT		1.4301 / AISI 304		blank / BRIGHT
3	1	Schraube / SCREW M4 x L		1.4567 / AISI 304		Fe/Zn 5 µm ·Cr(BRIGHT CHROMATE)

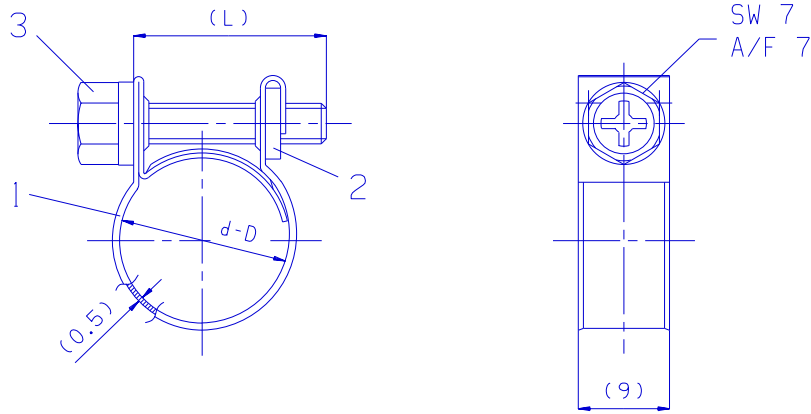

Empfohlenes Andrehmoment
RECOMMENDED TIGHTENING TORQUE

max 1.5 Nm

Empfohlene Einschraubgeschwindigkeit
RECOMMENDED TIGHTENING SPEED

max 350 1/min

Pos. POS.	L	d-D	Anliefer-ø +2 SHIPPING-ø +2	Bezeichnung PART-NAME	Teilnummer PART-NO.
1	12	7,5-8,5	8,5	MINI 8/9 C7 W4	0810 0002 008
2	12	8,5-9,5	9,5	MINI 9/9 C7 W4	0810 0002 009
3	12	9,5-11	11	MINI 10/9 C7 W4	0810 0002 010
4	16	10,5-12	12	MINI 11/9 C7 W4	0810 0002 011
5	16	11,5-13	13	MINI 12/9 C7 W4	0810 0002 012
6	16	12,5-14	14	MINI 13/9 C7 W4	0810 0002 013
7	16	13,5-15	15	MINI 14/9 C7 W4	0810 0002 014
8	16	14,5-16	16	MINI 15/9 C7 W4	0810 0002 015
9	16	15-17	17	MINI 16/9 C7 W4	0810 0002 016
10	20	16-18	18	MINI 17/9 C7 W4	0810 0002 017



ISSUE	QTY.	DESCRIPTION	Aend.-Nr. CHANGE-NO.	Datum DATE	Bearb. DRAWN	Gepr. CHECKED
C	1	screw length 20mm instead of 16 for size 017	01-609750	16.11.11	Krauss	Svensson
B	1	screw length 16mm instead of 20 for size 015/016/017 and thickness 0,5 instead of 0,4	01-608007	02.11.09	Krauss	Anderson
A	1	coating for part 3 add. / was drawing mistake / no changing of part	01-606950	15.08.08	Krauss	Hagmo

Projektions-Methode DIN 6	Allgemeintoleranz GENERAL TOLERANCE	Abwss fuer Winkel DEVIATION FOR ANGLE	Nennmassbereich/RANGE OF NOMINAL SIZES								
	ISO 2768-m		ueber/OVER	0,5	2,5	6,3	10,0	25,0	63,0	100,0	400,0
			bis/UP TO	2,5	6,3	10,0	25,0	63,0	100,0	400,0	1000,0

Gewicht: WEIGHT:	Material: siehe Stueckliste / SEE B.O.M.	PART NAME:												
	Material-No.:	MINI D/9 C7 W4												
	Oberflaeche: SURFACE QUAL.:	Benennung:												
	siehe Stueckliste / SEE B.O.M.	MINI D/9 C7 W4												
	<table border="1"> <tr> <th>Massstab: SCALE:</th> <th>Datum/DATE</th> <th>Name</th> </tr> <tr> <td>%</td> <td>02.07.07</td> <td>Krauss</td> </tr> <tr> <td></td> <td></td> <td>L.A.</td> </tr> <tr> <td></td> <td></td> <td>Norm</td> </tr> </table>	Massstab: SCALE:	Datum/DATE	Name	%	02.07.07	Krauss			L.A.			Norm	
Massstab: SCALE:	Datum/DATE	Name												
%	02.07.07	Krauss												
		L.A.												
		Norm												
	NDAMA													
	Schutzvermerk nach DIN 34 beachten													
	© COPYRIGHT BY RASMUSSEN GMBH													
Mit CIM/CAD erstellt	Zeichnungs-Nr./DRAWING-NO.:													
	0810 0002 000 C													
	DIN A3	Blatt: 1 1 Bl.												
	Ers.f.:	Ers.durch:												

Zeichnungs-Nr. / DRAWING-NO.:
0810 0002 000 C