

SWIFT-FIT

UNIVERSAL THREAD SYSTEM



ONE FITTING....ENDLESS POSSIBILITIES

NPTF • BSPP • BSPT • ISO 7 • ISO 228 • G Thread • J Thread



SWIFT-FIT

Inch Tube

Push-To-Connect Fittings with Inch Tube
Composite Release x Universal Thread System

COMPONENT SPECIFICATIONS

Pressure Rating: 0.99 - 15 Bar

Temperature Rating: -20°C / +80°C

Tubing Compatibility: Nylon*
Polyethylene*
Polyurethane*
Copper

*98 Durometer for best results

Media: Compressed Air
Water

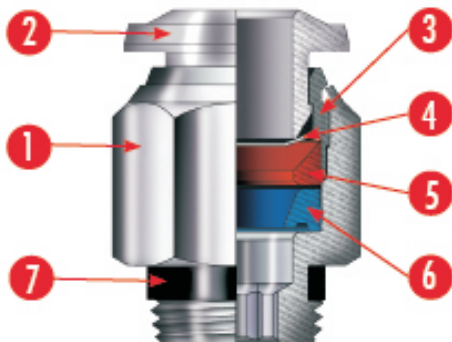

- | | |
|--------------------------|---------------------|
| 1. Body | Nickel Plated Brass |
| 2. Thrust Ring | Nickel Plated Brass |
| 3. Sleeve | Nickel Plated Brass |
| 4. Gripper Collet | Stainless steel |
| 5. Safety Ring | Technopolymer |
| 6. Lip Seal | NBR 70 |
| 7. Thread Seal | NBR 70 |

TUBE SIZES: THREAD SIZES:

Inch	1/8
1/8	1/4
5/32 (4mm)	3/8
1/4	1/2
5/16 (8mm)	
3/8	
1/2	

TORQUE SPECIFICATIONS

Threads		1/8	1/4	3/8	1/2
Min torque	(Nm)	5	5	5	5
	(Ft lbs)	3.7	3.7	3.7	3.7
Max torque	(Nm)	7	7	7	7
	(Ft lbs)	5.2	5.2	5.2	5.2

SAVE TIME.. SAVE MONEY.. USE SWIFT-FIT

- **No Stripped Fittings**
- **Quick Installation**
- **No Stripped Ports**
- **No Pitch Identification**
- **Completely Reusable**
- **Reduce Inventory**

SWIFT-FIT
Metallic

SAVE TIME.. SAVE MONEY.. USE SWIFT-FIT

- No Stripped Fittings
- No Stripped Ports
- Completely Reusable
- Quick Installation
- No Pitch Identification
- Reduce Inventory

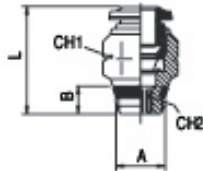
STRAIGHT MALE
SWIFT-FIT
Metallic

Part No.	Tube	A SWIFT	B	L	CH1	CH2	Conf/Pack
89000	1/8	1/8	.217 (5.5)	.850 (18.5)	.433 (11)	.079 (2)	25
89000	1/8	1/4	.276 (7)	.728 (18.5)	.551 (14)	.079 (2)	25
89000	5/32	1/8	.217 (5.5)	.708 (17.5)	.433 (11)	.118 (3)	25
89000	5/32	1/4	.276 (7)	.748 (19)	.551 (14)	.118 (3)	25
89000	1/4	1/8	.217 (5.5)	.846 (21.5)	.512 (13)	.157 (4)	25
89000	1/4	1/4	.276 (7)	.807 (20.5)	.551 (14)	.157 (4)	25
89000	1/4	3/8	.295 (7.5)	.905 (23)	.669 (17)	.157 (4)	25
89000	5/16	1/8	.217 (5.5)	.845 (24)	.551 (14)	.197 (5)	25
89000	5/16	1/4	.276 (7)	.846 (21.5)	.551 (14)	.236 (6)	25
89000	5/16	3/8	.295 (7.5)	.885 (22.5)	.669 (17)	.236 (6)	25
89000	3/8	1/8	.217 (5.5)	1.082 (27.5)	.669 (17)	.197 (5)	25
89000	3/8	1/4	.276 (7)	1.082 (27.5)	.669 (17)	.276 (7)	25
89000	3/8	3/8	.295 (7.5)	1.023 (25.5)	.669 (17)	.276 (7)	25
89000	3/8	1/2	.354 (9)	1.023 (25.5)	.827 (21)	.276 (7)	25
89000	1/2	1/4	.276 (7)	1.222 (31)	.787 (20)	.276 (7)	25
89000	1/2	3/8	.295 (7.5)	1.222 (31)	.787 (20)	.354 (9)	25
89000	1/2	1/2	.354 (9)	1.222 (31)	.827 (21)	.394 (10)	25

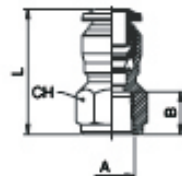
STRAIGHT FEMALE

Part No.	Tube	A NPTF	B	L	CH	Conf/Pack
89030	1/8	1/8	.374 (9.5)	.925 (24)	.512 (13)	25
89030	1/8	1/4	.531 (13.5)	1.142 (29)	.830 (16)	25
89030	5/32	1/8	.374 (9.5)	.965 (24.5)	.512 (13)	25
89030	5/32	1/4	.531 (13.5)	1.181 (29.5)	.830 (16)	25
89030	1/4	1/8	.374 (9.5)	1.063 (26)	.512 (13)	25
89030	1/4	1/4	.531 (13.5)	1.222 (31)	.830 (16)	25
89030	3/8	1/4	.531 (13.5)	1.358 (34.5)	.709 (18)	25
89030	3/8	3/8	.531 (13.5)	1.358 (34.5)	.787 (20)	25