



**CARATTERISTICHE TECNICHE**  
 TECHNICAL CHARACTERISTICS  
 TECHNISCHE ANGABEN  
 CARACTÉRISTIQUES TECHNIQUES  
 CARACTERÍSTICAS TÉCNICAS  
 CARACTERÍSTICAS TÉCNICAS



**Norma di Riferimento**  
 Reference standard  
 Entspricht der Norm  
 Norme de référence  
 Normativa de referencia  
 Norma de referência

1907/2006

REACH

2011/65/CE

RoHS

PED

2014/68/UE

ISO  
14743:2020

SILICON  
FREE

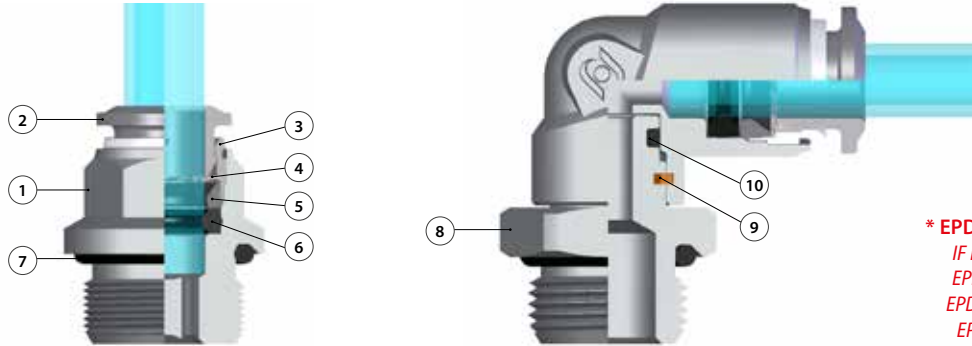

**\* EPDM A RICHIESTA**  
 IF REQUESTED EPDM  
 EPDM AUF ANFRAGE  
 EPDM SUR DEMANDE  
 EPDM BAJO PEDIDO  
 EPDM SOB ENCOMENDA

Materiali e Componenti	IT	Component Parts and Materials	GB	Komponenten und Materialien	DE
1 Corpo in ottone nichelato		1 Nickel-plated brass Body		1 Körper Messing vernickelt	
2 Spintore sgancio tubo in Ottone nichelato		2 Nickel-plated brass Collet		2 Rohr Lösering Messing vernickelt	
3 Capsula in ottone nichelato		3 Nickel-plated brass Capsule		3 Haltering Messing vernickelt	
4 Pinza d'aggraffaggio in acciaio inox AISI 301		4 Steel AISI 301 Clamping washer		4 Zahnscheibe Edelstahl AISI 301	
5 Anello di posizionamento in tecnopolimero		5 Technopolymeric positioning ring		5 Positionierring Technopolymer	
6 Guarnizione sagomata in NBR (EPDM a richiesta)		6 NBR Molded seal (if requested EPDM)		6 Lippendichtung NBR (EPDM auf Anfrage)	
7 Guarnizione filetto in NBR (EPDM a richiesta)		7 NBR Thread packing (if requested EPDM)		7 Gewindeabdichtung NBR (EPDM auf Anfrage)	
8 Basetta Filettata in Ottone Nichelato		8 Base Threaded Nickel Plated Brass		8 Gewindebasis Messing vernickelt	
9 Seeger		9 Seeger		9 Seeger	
10 Guarnizione in NBR (EPDM a richiesta)		10 NBR seal (if requested EPDM)		10 Lippendichtung NBR (EPDM auf Anfrage)	

Matériaux et Composants	FR	Materiales y Componentes	ES	Materiais e Componentes	PT
1 Corps: Laiton nickelé		1 Cuerpo en latón niquelado		1 Corpo em latão niquelado	
2 Pousoir: Laiton nickelé		2 Anillo de extracción tubo en latón niquelado		2 Anilha de liberação em latão niquelado	
3 Capsule de retenue: Laiton nickelé		3 Cápsula en latón niquelado		3 Cápsula de latão niquelado	
4 Rondelle d'accrochage: AISI 301		4 Pinza de agarre en acero inox AISI 301		4 Pinça de travamento em aço-inox AISI 301	
5 Anneau de positionnement: Technopolymère		5 Anillo de posicionamiento en tecnopolímero		5 Anel de posicionamento em tecnopolímero	
6 Joint à lèvre: NBR (EPDM sur demande)		6 Junta de forma en NBR (EPDM bajo pedido)		6 Vedação em NBR (EPDM sob encomenda)	
7 Joint d'étanchéité du filetage: NBR (EPDM sur demande)		7 Junta rosca en NBR (EPDM bajo pedido)		7 Vedação da rosca em NBR (EPDM sob encomenda)	
8 Bague de sécurité en laiton nickelé		8 Base roscada en latón niquelado		8 Base roscada em latão niquelado	
9 Seeger		9 Seeger		9 Seeger	
10 Joint en NBR (EPDM sur demande)		10 Junta en NBR (EPDM bajo pedido)		10 Vedação em NBR (EPDM sob encomenda)	



**Pressioni**

Pressures  
 Druckbereich  
 Pressions  
 Presiones  
 Pressões

**- 0.99 bar** (-0.099 MPa)  
**20 bar** (2.0 MPa)



**Fluidi compatibili**

Aria compressa / Vuoto / Acqua / Vapore (EPDM)

Fluids  
 Compressed air / Vacuum / Water / Steam (EPDM)

Geeignete Medien  
 Druckluft / Vakuum / Wasser / Dampf (EPDM)

Fluides compatibles  
 Air comprimé / Vide / Eau / Vapeur (EPDM)

Fluidos compatibles  
 Aire comprimido / Vacío / Agua / Vapor (EPDM)

Fluidos compatíveis  
 Ar comprimido / Vácuo / Água / Vapor (EPDM)



**Temperature**

Temperatures  
 Temperatur  
 Températures  
 Temperaturas  
 Temperaturas

**- 20 °C**  
**+ 80 °C**

**EPDM**  
**- 40 °C**  
**+ 130 °C**



**Tubi di Collegamento**

Tubi in materiale plastico:  
 PA6, PA11, PA12, Polietilene, \*Poliuretano, PTFE, FEP.  
 \*Utilizzo da 90 a 98 Shore, per la massima prestazione è consigliato 98 Shore A.

**Connection Tubes**

Plastic tubes:  
 PA6, PA11, PA12, Polyethylene, \*Polyurethane, PTFE, FEP.  
 \*Use from 90 to 98 Shore, for maximum performance is recommended 98 Shore A.

**Geeignete Rohre**

Kunststoffrohre:  
 PA6, PA11, PA12, Polyethylene, \*Polyurethan, PTFE, FEP.  
 \*Verwenden Sie 90 bis 98 Shore, für maximale Leistung wird 98 Shore A empfohlen.

**Tubes Conseillés**

Tubes plastiques:  
 PA6, PA11, PA12, Polyéthylène, \*Polyuréthane, PTFE, FEP.  
 \*Utilisation de 90 à 98 Shore, pour une performance maximale recommandée 98 Shore A.

**Tubos de Conexión**

Tubos en material plástico:  
 PA6, PA11, PA12, Polietileno, \*Poliuretano, PTFE, FEP.  
 \*Uso de 90 a 98 Shore, para un máximo rendimiento se recomienda 98 Shore A.

**Tubos de Conexão**

Tubos em material plástico:  
 PA6, PA11, PA12, Polietileno, \*Poliuretano, PTFE, FEP.  
 \*Uso de 90 a 98 Shore, para o desempenho máximo é recomendado 98 Shore A.



<b>Filettatura</b> Gas conica "UNIVERSAL SHORT". Gas conica conforme ISO 7.1, BS 21, DIN 2999. Gas cilindrica conforme ISO 228 Classe A. Metrica conforme ISO R/262.	<b>IT</b>	<b>Threads</b> "UNIVERSAL SHORT" Tapered thread. Tapered gas in conformity with ISO 7.1, BS 21, DIN 2999. Parallel gas in conformity with ISO 228 Class A. Metric in conformity with ISO R/262.	<b>GB</b>	<b>Gewindearten</b> Konisches Gewinde "UNIVERSAL SHORT". Konisches Gewinde nach Norm ISO 7.1, BS 21, DIN 2999. Zylindrisches Gewinde nach Norm ISO 228 Classe A. Metrisches Gewinde nach Norm ISO R/262.	<b>DE</b>
<b>Filetages</b> Filetage conique "UNIVERSAL SHORT". Filetage conique conforme: ISO 7.1, BS 21, DIN 2999. Filetage cylindrique conforme: ISO 228 Class A. Filetage métrique conforme: ISO R/262.	<b>FR</b>	<b>Roscas</b> Gas cónica "UNIVERSAL SHORT". Gas cónica conforme ISO 7.1, BS 21, DIN 2999. Gas cilíndrica conforme ISO 228 Clase A. Métrica conforme ISO R/262.	<b>ES</b>	<b>Roscas</b> Gas cónica "UNIVERSAL SHORT". Gas cónica conforme ISO 7.1, BS 21, DIN 2999. Gas paralela conforme ISO 228 Classe A. Métrica conforme ISO R/262.	<b>PT</b>



**UNIVERSAL SHORT**

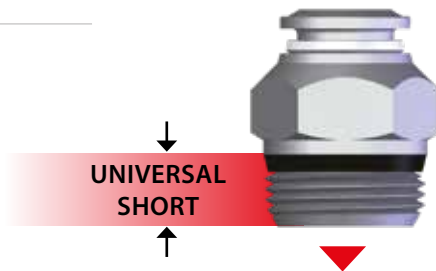

<p><b>NPT</b> <b>NPTF</b></p>	Conica Tapered Konisch Conique Cónica Cônica	<p><b>ISO 7</b> <b>BSPP</b></p>	Cilíndrica Paralell Zylindrisch Cylindrique Cilíndrica Paralela	<p><b>ISO 7</b> <b>BSPT</b> <b>PT</b></p>	Conica Tapered Konisch Conique Cónica Cônica	<p><b>ISO 228</b> <b>BSP</b> <b>PF</b></p>	Cilíndrica Paralell Zylindrisch Cylindrique Cilíndrica Paralela
-----------------------------------	---	-------------------------------------	--	---	---	--	--

<b>"UNIVERSAL SHORT"</b> La filettatura conica "UNIVERSAL SHORT" è progettata per soddisfare le seguenti caratteristiche: <ul style="list-style-type: none"> <li>• ridurre la lunghezza d'ingombro;</li> <li>• ridurre la chiave rispetto ad alcuni raccordi con filettature cilindriche;</li> <li>• consentire l'accoppiamento con diversi standard di filettature femmina sia coniche che cilindriche.</li> </ul>	<b>IT</b>	<b>"UNIVERSAL SHORT"</b> The "UNIVERSAL SHORT" taper thread has been designed to offer the following advantages to the users: <ul style="list-style-type: none"> <li>• reduced overall length;</li> <li>• smaller hex dimensions compared to the parallel threads;</li> <li>• to allow the assembly with different female threads both taper as well as parallel.</li> </ul>	<b>GB</b>	<b>"UNIVERSAL SHORT"</b> Das konische Gewinde "UNIVERSAL SHORT" ist so konzipiert, dass folgende Vorteile erzielt werden: <ul style="list-style-type: none"> <li>• Reduzierung der Länge des Gewindes - kürzere Montagezeit;</li> <li>• Reduzierung der Schlüsselweite im Vergleich von Verschraubungen mit zylindrischen Gewinden - geringerer Lochabstand;</li> <li>• Ermöglicht den Einsatz in verschiedene Gewindearten, sowie in konische- und zylindrische Innengewinde.</li> </ul>	<b>DE</b>
<b>"UNIVERSAL SHORT"</b> Le filetage conique "UNIVERSAL SHORT" a été conçu pour satisfaire les exigences suivantes: <ul style="list-style-type: none"> <li>• réduire la longueur d'encombrement;</li> <li>• réduire les dimensions hexagonales par rapport au filetage cylindrique;</li> <li>• permettre le montage avec divers taraudages standards soit coniques soit cylindriques.</li> </ul>	<b>FR</b>	<b>"UNIVERSAL SHORT"</b> La rosca cónica "UNIVERSAL SHORT" ha sido proyectada para satisfacer las siguientes características: <ul style="list-style-type: none"> <li>• reducir la longitud;</li> <li>• reducir la llave respecto a algunos racores con rosca cilíndrica;</li> <li>• permitir el acoplamiento con diferentes standard de rosas hembra sean cónicas o cilíndricas.</li> </ul>	<b>ES</b>	<b>"UNIVERSAL SHORT"</b> A rosca cónica "UNIVERSAL SHORT" é projetada para satisfazer às seguintes características: <ul style="list-style-type: none"> <li>• reduzir o comprimento da conexão;</li> <li>• reduzir o dimensional com relação às rosas paralelas;</li> <li>• permitir o acoplamento da conexão a diferentes tipos de rosca fêmea, sejam elas cónicas ou paralelas.</li> </ul>	<b>PT</b>



Consentire una completa tenuta anche su superfici non perfettamente piane, concave, convesse o inclinate, con diversi smussi o raggi.	<b>IT</b>	To ensure the right tightening also with surfaces not perfectly flat, without spot-facing, concave convex and with different kinds of chamfers or radius.	<b>GB</b>	Eine vollständige Abdichtung ist auch auf unebenen Flächen, wie geneigt, konkav oder konvex und mit unterschiedlichen Radien oder Fasen gewährleistet.	<b>DE</b>
Pour permettre une parfaite étanchéité même sur des surfaces non planes, concaves, convexas ou inclinées et avec différents chanfreins ou rayons.	<b>FR</b>	Consentir una completa estanqueidad incluso en superficies no perfectamente planas, cóncavas, convexas o inclinadas, con diferentes ángulos o radios.	<b>ES</b>	Permite um aperto correto em superfícies não perfeitamente planas, côncavas, convexas ou inclinadas, com diferentes chanfros ou raios.	<b>PT</b>



### Coppia di serraggio

Torque specifications

Angaben Drehmoment

Couple de serrage

Par de apriete

Especificações de Torque



ISO 228



"UNIVERSAL SHORT"

I valori di rottura possono variare in base all'articolo  
*Breaking values may vary according to the item*  
 Die maximal werte dienen nur zu informationszwecken  
*Les valeurs maximales sont présentées à titre indicatif*  
 Los valores de rotura pueden variar en función del artículo  
*Los valores de força pode variar em função artigo*

MISURA MEASURE GRÖSSE DIMENSIONS MEDIDA MEDIDA	COPPIA CONSIGLIATA Nm RECOMMENDED TORQUE Nm EMPFOHLENES DREHMOMENT Nm COUPLE DE SERRAGE Nm PAR ACONSEJADO Nm TORQUE RECOMENDADO Nm	COPPIA DI ROTTURA Nm BREAKING TORQUE Nm ABSCHERDREHMOMENT Nm COUPLE DE RUPTURE Nm PAR DE ROTURA Nm BINÁRIO ROMPER Nm
M5	0,8	3,2
M7	3	8
M8	3	8
1/8	3	8
1/4	9	30
3/8	10	60
1/2	12	50

MISURA MEASURE GRÖSSE DIMENSIONS MEDIDA MEDIDA	COPPIA MINIMA CONSIGLIATA Nm RECOMMENDED MINIMUM TORQUE Nm EMPFOHLENES DREHMOMENT Nm COUPLE DE SERRAGE Nm PAR MÍNIMO ACONSEJADO Nm TORQUE MÍNIMO RECOMENDADO Nm	COPPIA MASSIMA CONSIGLIATA Nm RECOMMENDED MAX TORQUE Nm ABSCHERDREHMOMENT Nm COUPLE DE RUPTURE Nm PAR MÁXIMO ACONSEJADO Nm TORQUE MÁXIMA RECOMENDADO Nm
1/8	5	7
1/4	5	7
3/8	5	7
1/2	5	7

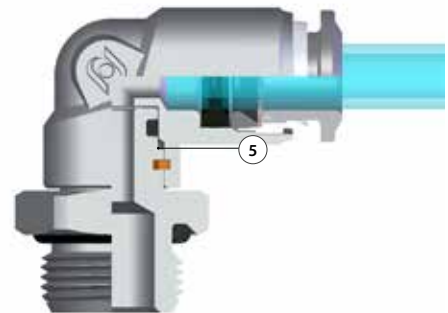
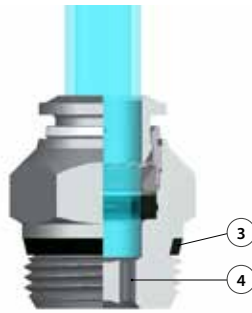
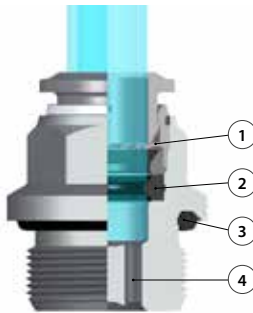

### Vantaggi

IT

- 1 La pinza in acciaio inox garantisce il perfetto aggiraffaggio di tubi di qualsiasi materiale senza danneggiarne la superficie. Il collegamento tra tubo e raccordo assicura una tenuta totale anche in condizioni di urti e vibrazioni.
- 2 La particolare geometria della guarnizione permette inoltre l'utilizzo dei raccordi anche con il vuoto.
- 3 Tutte le filettature di questa serie sono state dotate di elementi di tenuta che permettono l'immediato utilizzo dei raccordi riducendo notevolmente i tempi di installazione.
- 4 Tutti i raccordi dritti possono essere montati anche con chiave esagonale ed è possibile utilizzarli anche in spazi molto ridotti.
- 5 Raccordo orientabile con anello di sicurezza interno. Garantisce maggiore durata alla rotazione e trazione.

### Advantages

GB

- 1 The washer is made in stainless steel ensures the perfect tube clamping with every kinds of materials without damage the surface. The connection between the tube and the fitting ensure a total tightness even in severe conditions such as impact and vibrations.
- 2 The particular geometric shape of the seal ensure the perfect tightness even with vacuum.
- 3 All of threads from this range have been equipped with tightening parts which allow the direct assembly of the fittings, reducing the installation time.
- 4 All the straight fittings can be assembled also with Allen wrench and it is possible to use them in reduced spaces.
- 5 Orienting fitting with safety ring inside. Improved durability to the rotation and traction.

### Vorteile

DE

- 1 Konisches Gewinde "kurz" Die Zahnscheibe sorgt für eine perfekte Halterung des Rohres ohne die Oberfläche zu beschädigen. Die Dichtigkeit zwischen Rohr und Verschraubung ist auch bei Erschütterungen und Vibrationen gewährleistet.
- 2 Die besondere Geometrie der Dichtung ermöglicht auch die Anwendung der Verschraubungen in Verbindung mit Vakuum.
- 3 Alle Verschraubungen in dieser Serie sind mit Gewindeabdichtungen ausgestattet, die den sofortigen Einsatz ermöglichen und daher die Montagezeit stark reduzieren.
- 4 Alle geraden Verschraubungen können auch mit Inbusschlüsseln montiert werden, daher kleiner Lochabstand möglich.
- 5 Flexible Montage mit Sicherungsring innen. Verbesserte Beständigkeit gegenüber der Drehung und Traktions.

### Avantages

FR

- 1 La rondelle en acier inoxydable garantit la parfaite tenue du tube quelle que soit la matière et sans l'endommager. La connexion entre le tube et le raccord assure une étanchéité totale même dans des conditions d'impact ou de vibrations.
- 2 La spécificité géométrique du joint permet l'utilisation des raccords avec le vide.
- 3 Tous les filetages de cette série sont équipés d'éléments d'étanchéité qui permettent l'utilisation immédiate des raccords réduisant ainsi le temps d'installation.
- 4 Tous les raccords droits peuvent être aussi montés avec une clé hexagonale pour permettre une utilisation dans des espaces réduits.
- 5 Accessoire de fixation réglable avec anneau de sécurité à l'intérieur. Amélioration de la durée de la rotation et de traction.

### Ventajas

ES

- 1 La pinza en acero inox garantiza el perfecto agarre del tubo de cualquier material sin perjudicar la superficie. La conexión entre tubo y racor asegura una estanqueidad total aun en condiciones de impacto o vibración.
- 2 La particular geometría de la junta garantiza una perfecta estanqueidad incluso en vacío.
- 3 Todas las rosas de esta serie están fabricadas con junta de cierre que permite la inmediata utilización del racor reduciendo notablemente el tiempo de instalación.
- 4 Todos los racores rectos pueden montarse también con llave hexagonal y es posible utilizarlos incluso en espacios muy reducidos.
- 5 Montaje ajustable con sistema de seguridad interior. La mejora de la durabilidad a la rotación y tracción.

### Vantagens

PT

- 1 A pinça em aço-inox garante o perfeito travamento do tubo de qualquer material sem danificar a superfície do mesmo. A conexão entre o tubo e a conexão assegura uma vedação total também em condições de impactos e vibrações.
- 2 A geometria particular da vedação permite a utilização da conexão também para aplicações com vácuo.
- 3 Todas as rosas desta série são dotadas de elementos de vedação, o que permite a imediata utilização das conexões, reduzindo notavelmente o tempo de instalação.
- 4 Todas as conexões retas podem ser montadas também com chave allenando possível montagem das mesmas em espaços bem reduzidos.
- 5 Montagem ajustável com anel de segurança dentro. A durabilidade melhorada para a rotação e tração.

## 57310

**RACCORDO A Y INTERMEDIO**  
 Y CONNECTOR  
 Y-ANSCHLUSS  
 RACCORD Y SIMPLE  
 RACOR A Y INTERMEDIO  
 CONEXÃO EM "Y" TUBO-TUBO

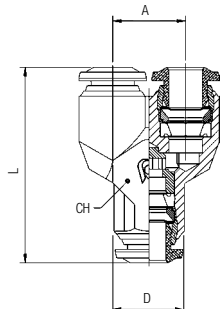

Code	Tube	A	L	CH	D	Pack.
* 57310 00 001	4 (5/32)	11	32	11	10	10
57310 00 004	5	13.5	35	13	12.5	10
57310 00 002	6	13.5	36.5	13	12.5	10
* 57310 00 003	8 (5/16)	15.5	41	15	14	10
57310 00 008	10	18.5	48	18	17	10

## 57326

**RACCORDO A Y ORIENTABILE MASCHIO CILINDRICO**  
 Y CONNECTOR MALE ADAPTOR (PARALLEL)  
 Y-ANSCHLUSS ZYLINDRISCH (DREHBAR)  
 RACCORD Y SIMPLE MÂLE, CYLINDRIQUE  
 RACOR A Y ORIENTABLE MACHO CILÍNDRICO CON TÓRICA  
 CONEXÃO MACHO EM "Y" ORIENTÁVEL COM ROSCA PARALELA

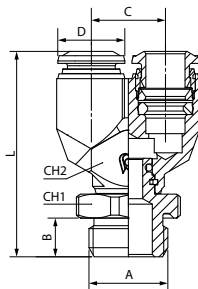

Code	Tube	A	B	C	CH1	CH2	D	Pack.
57326 00 003	4	1/8	5.4	32.5	13	11	10	10
57326 00 008	6	1/8	5.4	37	13	13	12.5	10
57326 00 009	6	1/4	7.1	38.5	16	13	12.5	10
57326 00 010	8	1/8	5.4	40.5	13	15	14	10
57326 00 011	8	1/4	7.1	41	16	15	14	10
70326 00 012	8	3/8	8.1	43	20	15	14	10

## 57500

**ANELLO A L ORIENTABILE**  
 SINGLE BANJO BODY  
 RINGANSCHLUSS  
 CORPS SIMPLE POUR BANJO  
 ANILLO ORIENTABLE SIMPLE  
 ANEL ORIENTÁVEL EM "L"

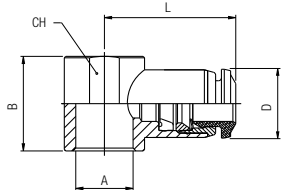

Code	Tube	A	B	L	CH	D	Pack.
* 57500 00 001	4 (5/32) M5(10/32)	12.5	19	19	-	10	10
57500 00 002	4 M6	12.5	19	19	-	10	10
* 57500 00 003	4 (5/32) 1/8	15	21	21	14	10	10
57500 00 013	5 M5	12.5	20	20	-	12.5	10
57500 00 017	5 M6	12.5	20	20	-	12.5	10
57500 00 014	5 1/8	15	21.5	21.5	14	12.5	10
57500 00 015	5 1/4	17	24.5	24.5	18	12.5	10
57500 00 016	6 M5	12.5	20.5	20.5	-	12.5	10
57500 00 018	6 M6	12.5	20.5	20.5	-	12.5	10
57500 00 004	6 1/8	15	22	22	14	12.5	10
57500 00 005	6 1/4	17	25	25	18	12.5	10
* 57500 00 006	8 (5/16) 1/8	15	24	24	14	14	10
* 57500 00 007	8 (5/16) 1/4	17	26	26	18	14	10
* 57500 00 008	8 (5/16) 3/8	20	28	28	21	14	10
57500 00 009	10 1/4	17	29	29	18	17	10
57500 00 010	10 3/8	20	30.5	30.5	21	17	10
57500 00 012	12 3/8	20	32.5	32.5	21	21.5	10
57500 00 021	12 1/2	24	35	35	25	21.5	10
57500 00 022	14 1/2	24	35.5	35.5	25	21.5	10

## 57510

**ANELLO A T ORIENTABILE**  
 DOUBLE BANJO BODY  
 DOPPELTER RINGANSCHLUSS  
 CORPS DOUBLE POUR BANJO  
 ANILLO ORIENTABLE DOBLE  
 ANEL ORIENTÁVEL EM "T"

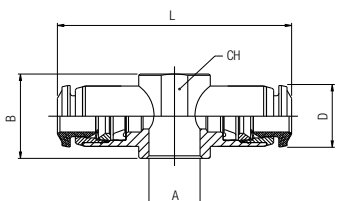

Code	Tube	A	B	L	CH	D	Pack.
* 57510 00 001	4 (5/32) M5	12.5	38	38	-	10	10
* 57510 00 002	4 (5/32) M6	12.5	38	38	-	10	10
* 57510 00 003	4 (5/32) 1/8	15	42	42	14	10	10
57510 00 008	5 1/8	15	43	43	14	12.5	10
57510 00 009	5 1/4	17	49	49	18	12.5	10
57510 00 004	6 1/8	15	44	44	14	12.5	10
57510 00 005	6 1/4	17	50	50	18	12.5	10
* 57510 00 006	8 (5/16) 1/8	15	48	48	14	14	10
* 57510 00 007	8 (5/16) 1/4	17	52	52	18	14	10